

Operation & Maintenance Manual

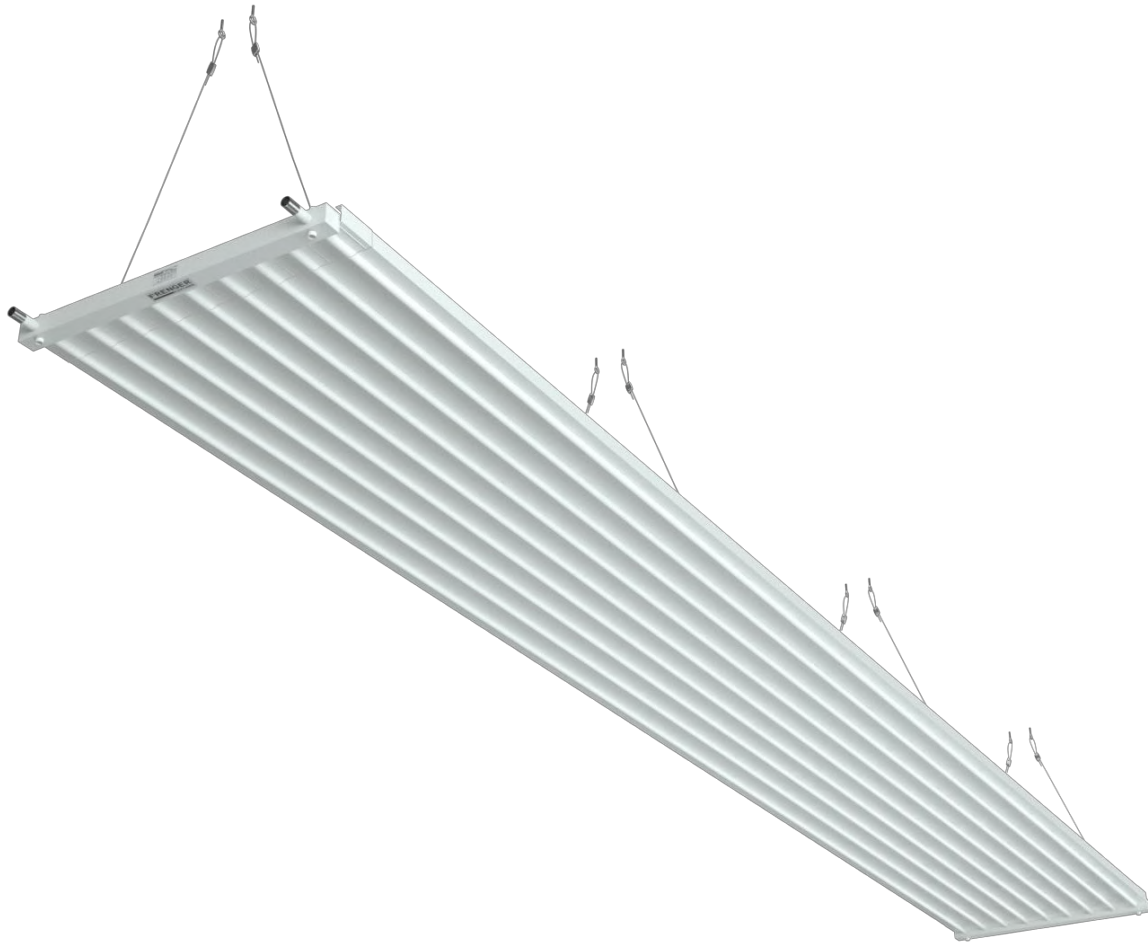

EcoStrip XP Radiant Heating Panel

Frenger Systems Limited	1			
Riverside Road, Pride Park, Derby	Telephone	Facsimile	E-mail	Internet
DE24 8HY, United Kingdom	+44 (0) 1332 295 678	+44 (0) 1332 381 054	Technical@frenger.co.uk	www.frenger.co.uk

Contents

Contents.....2
 General3
 Parts Diagram4
 Materials5
 Air Venting.....6
 Safety Specifications6
 Transport and Storing.....6
 Connection procedure7
 Suspensions.....8
 Gradient, Air vents and water drains.....8
 Assembly and Installation Instructions9
 Mounting Height9
 Standard Version for Pressfittings10
 Special Version for Welding10
 Panel Dimensions11
 Header & Connections15
 Weight and Water Content15
 Thermal Emission.....16
 Maintenance and Cleaning.....18
 Water Quality18
 Replacement Parts.....18
 Contact Details.....19

Frenger Systems Limited	2			
Riverside Road, Pride Park, Derby	Telephone	Facsimile	E-mail	Internet
DE24 8HY, United Kingdom	+44 (0) 1332 295 678	+44 (0) 1332 381 054	Technical@frenger.co.uk	www.frenger.co.uk

General

The project will utilise Frenger EcoStrip XP Water Driven Radiant Heating Panels.

EcoStrip XP is a robust radiant panelling system ideal for the heating of larger building such as warehouses, production facilities and hangers.

The EcoStrip XP panel warms the environment by both radiant and convective heat transfer (approximately 70%/30% respectively). The heat radiation is absorbed by the surrounding colder surfaces, and natural convection heats the passing room air.

Each EcoStrip XP panel is available in two versions (standard or special) and is comprised of steel pipes pressed into semicircular sockets on the panel, creating a pipe work circuit. The panel sockets are created by mechanically forming cold formed steel (panels with 18mm pipework are 0.8mm thick, panels with 28mm pipework are 1.2mm thick) into the widths ranging from 300mm – 1500mm as standard. Section lengths of 4-6m as standard are then suitable for interconnection to create larger panel run lengths. Each panel run will include main connection and return headers.

Warm water is subsequently supplied through the steel tube pathways at the appropriate temperature and with sufficient mass flow rate to obtain turbulent flow to facilitate heat transfer thus creating radiant and convective heat output.

Frenger Systems Limited	3			
Riverside Road, Pride Park, Derby	Telephone	Facsimile	E-mail	Internet
DE24 8HY, United Kingdom	+44 (0) 1332 295 678	+44 (0) 1332 381 054	Technical@frenger.co.uk	www.frenger.co.uk

Parts Diagram

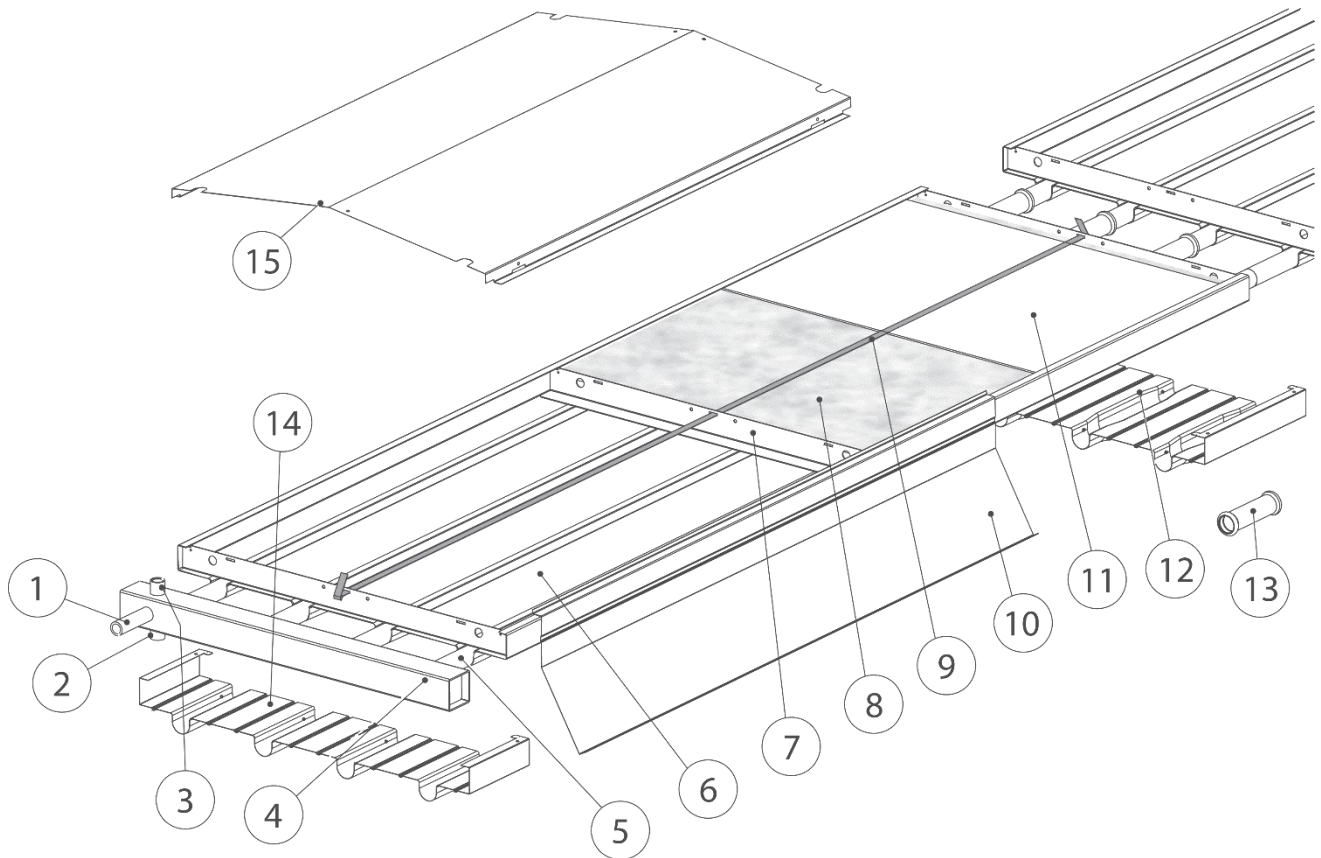

- 1 - Threaded male connections (3/4", 1" & 1 1/4") – See page 15 for header types
- 2 - Water drain connection 3/8" (Customer to supply and fit either 3/8" drain cock or 3/8" brass plug)
- 3 - Air vent connections 3/8" (Customer to supply and fit either 3/8" air vent or 3/8" brass plug)
- 4 - First or end header
- 5 - Steel pipe
- 6 - Steel radiant panel
- 7 - Hanging bracket
- 8 - Pre-fitted 40mm thick foil faced insulation
- 9 - Insulation retaining clip
- 10 - Anti-convective skirts (on request)
- 11 - Flat cover (on request)
- 12 - Make-up joint between panel and header
- 13 - Ball guard (on request)

Frenger Systems Limited	4			
Riverside Road, Pride Park, Derby	Telephone	Facsimile	E-mail	Internet
DE24 8HY, United Kingdom	+44 (0) 1332 295 678	+44 (0) 1332 381 054	Technical@frenger.co.uk	www.frenger.co.uk

Materials

EcoStrip XP is available in two versions: -

Standard: - Suitable for operating pressures of 10 bar and a maximum hot water temperature of 120°C.

Special: - Suitable for operating pressures of 16 bar and high temperature hot water from 120°C to 180°C.

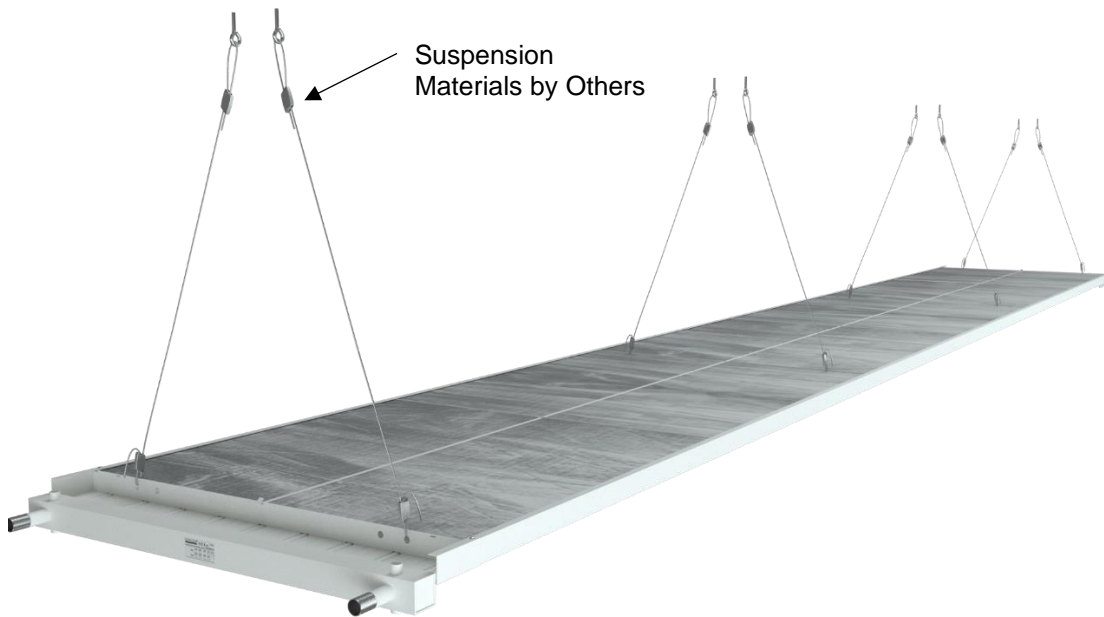

The standard version is available with either “Belled” ends (to ease the longitude end connections of the strips with welding) or standard pipe (work to allow for the use of appropriate compatible press fitting systems. Contact our technical department for further details of suitable press fitting systems). The special version is supplied with “Belled” ends.

Each panel run will arrive with two sets of headers, however when longer lengths of panel are required intermediate sections will be provided with straight runs of pipe work only.

EcoStrip XP is powder coated as standard in RAL9016 (white), although other RAL colours can be accommodated on request.

The face plate in either version is made up using quality steel radiant panel (0.8mm thick for 18mm pipes and 1.2mm for 28mm pipes), cold formed by mechanical forming procedure. The panel face is formed in semicircular self-locking sockets, spaced 100 or 150mm apart depending on the models, which are used to hold the pipes that carry the hot water.

The panels are supplied with pre-fitted fibreglass insulation (30 or 40 thick) with a fire rating of A1 protected at the top by aluminium sheet; other thickness or configurations are available upon request.

Approximate emissivity of radiant surface is: 0.96

Frenger Systems Limited	5			
Riverside Road, Pride Park, Derby	Telephone	Facsimile	E-mail	Internet
DE24 8HY, United Kingdom	+44 (0) 1332 295 678	+44 (0) 1332 381 054	Technical@frenger.co.uk	www.frenger.co.uk

Air Venting

Arrange for venting through the circulating system

Safety Specifications

Due to the size and weight of the product (see table page 15), each panel section should be lifted/positioned as required with due care and attention taken in respect to onsite Health & Safety regulations (i.e. PPE requirements).

Panel sections should be stored in a cool, dry environment using the original packaging. Each stack of panels should be positioned on a flat and even surface ensuring the stability of the stack on site.

When installing the radiant panels please ensure that all on site Health & Safety standards are adhered to. Take all necessary precautions of safety when installing heavy material at high level.

To avoid damage to an assembled radiant panel do not walk/trample over a packaged product.

Transport and Storing

Please ensure that the materials delivered correspond to your order upon receipt. The unloading of any radiant panel is the responsibility of the customer unless otherwise stated and agreed as part of the contract.

Panel sections will arrive palletised with cardboard separators between each section. All radiant panels are suitable for internal use only and should be safely stored, prior to installation, within a dry and secure indoor environment.

Never attempt to move any radiant panel section as an individual, always adhere to the Health & Safety regulations on your site.

Frenger Systems Limited	6			
Riverside Road, Pride Park, Derby	Telephone	Facsimile	E-mail	Internet
DE24 8HY, United Kingdom	+44 (0) 1332 295 678	+44 (0) 1332 381 054	Technical@frenger.co.uk	www.frenger.co.uk

Connection procedure

The EcoStrip XP standard version can be operated with hot water at a maximum temperature of 120°C and a hydraulic pressure of no more than 10 bar. The EcoStrip XP special version can be operated with hot water at a maximum temperature of 180°C and a hydraulic pressure of 16 bar.

Any panels with D-headers are not suitable for operation with high temperature hot water.

Panels should be connected to the mains using suitable connectors. However, we do recommend that to avoid problems due to the different expansion of each panel-run, when starting from cold, the water outlet temperature through the panel can easily reach 45°C without limitation. When increasing the water temperature from 45°C to 85°C ensure the increase is staggered at maximum of 10°C every 3 minutes if using B Header and 10°C every 4 minutes if using D Header.

The supply tubes must be mounted in such way to absorb the movements caused by thermal expansions if necessary, introduce an expansion joint to the circuit.

On the entrance header near the upper threaded joint an Ø 3/8" air vent has to be mounted, which eliminates the air from the circuit and on the exit header below, a Ø 3/8" drain cock will be required; all other open Ø 3/8" joints should be closed using brass plugs supplied by others.

Frenger Systems Limited	7			
Riverside Road, Pride Park, Derby	Telephone	Facsimile	E-mail	Internet
DE24 8HY, United Kingdom	+44 (0) 1332 295 678	+44 (0) 1332 381 054	Technical@frenger.co.uk	www.frenger.co.uk

Suspensions

Hanging Installation

The EcoStrip XP radiant heating panel can be suspended in various different ways; note no chains/rods/wires are supplied with the panel. The below information is for guidance only. The panels should be suspended as a minimum every 2 meters utilising the upper hanging brackets on the panel (these are positioned every meter on the panel runs). There is a recommended minimum length of suspension to allow for thermal expansion of the panels, please see our product literature for exact details and further information.

Distance between radiant panels

Tests and practice have shown that an even distribution of radiant heat over a central area in a building (where the cooling effect of the walls can be considered as 0) is achieved when the distance between EcoStrip XP panels is the same or less than the height from the floor. For example when EcoStrip XP panels are installed at a height of 4m from the floor then the distance between the panels must be 4m or less to obtain the best heating coverage.

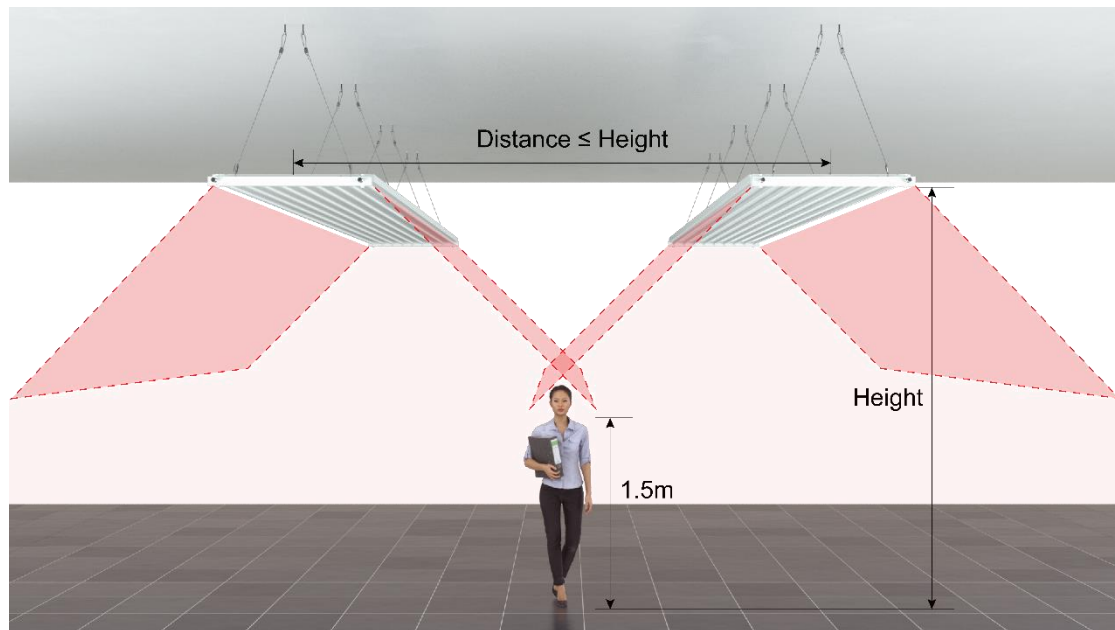

Gradient, Air vents and water drains

EcoStrip XP, having the pipes connected together in parallel using a header, must be installed as follows: -

- The transversal axis, even in the case of horizontal installation, must have a slight upwards gradient towards the supply of the hot water.
- The longitude axis must have an upward gradient towards the supply of hot water.

The hot water supply connections are therefore always at the highest point of the installation, so as to assist the air venting, while return connection is always the lowest point, and can therefore be used for draining. The radiant panel supply pipes must be designed so as to absorb the thermal expansions without affecting the heating elements.

Frenger Systems Limited	8			
Riverside Road, Pride Park, Derby	Telephone	Facsimile	E-mail	Internet
DE24 8HY, United Kingdom	+44 (0) 1332 295 678	+44 (0) 1332 381 054	Technical@frenger.co.uk	www.frenger.co.uk

Assembly and Installation Instructions

For assembly and installation information see Frenger's latest "Instructions for Installation" guide.

Mounting Height

The EcoStrip XP radiant panels must be installed, based on the temperature of the hot water, as low as possible so as to reduce the loss of radiant heat due to the presence of dust in the air underneath the strip. Excepting the reduction in efficiency due to micro-particles in the air that may not absorb a minimal part of the radiant emission, there are no limits to the height of installation.

In fact, if the height of installation of a hypothetical radiant ceiling were moved upwards, the surface that radiates heat onto people below would increase proportionally to the square of the height above such people, while the intensity of radiation received by the people and emitted by each unit of the radiant ceiling would decrease proportionally to the square of the distance from the people; based on these laws of physics, the total radiant heat received by the people thus remains constant. Vice-versa, there are limits in terms of the minimum height of installation for the radiant units according to the average temperature values of hot water.

The minimum recommended values, for the two models ESXP-03 and ESXP-04, are shown in the table below valid for the horizontal installation and in the case of people working in stationary positions.

Mean Water Temp °C	ESXP-03-03 ESXP-04-03	ESXP-03-06 ESXP-03-09 ESXP-04-06	ESXP-03-12 ESXP-04-09	ESXP-03-15 ESXP-04-12
60 °C	3.0	3.1	3.2	3.3
70 °C	3.1	3.2	3.3	3.4
80 °C	3.2	3.3	3.4	3.5
90 °C	3.3	3.5	3.7	3.8
100 °C	3.4	3.7	3.9	4.0
110 °C	3.5	4.0	4.3	4.4

Frenger Systems Limited	9			
Riverside Road, Pride Park, Derby	Telephone	Facsimile	E-mail	Internet
DE24 8HY, United Kingdom	+44 (0) 1332 295 678	+44 (0) 1332 381 054	Technical@frenger.co.uk	www.frenger.co.uk

Standard Version for Pressfittings

As standard the radiant panels are supplied with straight pipes, so as to allow the panels to be joined by press fittings, allowing quick and precise assembly and consequently saving in labour costs. Panels can upon request be supplied with belled ends to allow joining by welding.

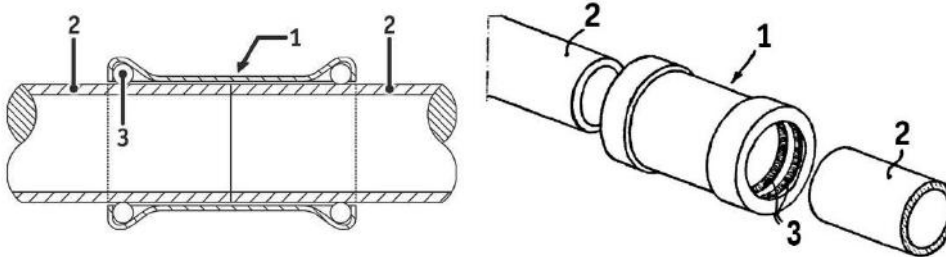

1. Linear connection (to be supplied and fitted by customer)
2. Pipes to be joined
3. O-Rings seals EPDM

For advice on compatible press fittings, please contact our technical sales department.

Special Version for Welding

For higher temperature water (120°C to 180°C), our EcoStrip XP radiant panels are supplied with 'special' pipe water interconnections. These interconnections are to be butt welded on site by others.

Frenger Systems Limited	10			
Riverside Road, Pride Park, Derby	Telephone	Facsimile	E-mail	Internet
DE24 8HY, United Kingdom	+44 (0) 1332 295 678	+44 (0) 1332 381 054	Technical@frenger.co.uk	www.frenger.co.uk

Panel Dimensions

Model ESXP-03 - Ø18mm pipes spaced 100mm apart.

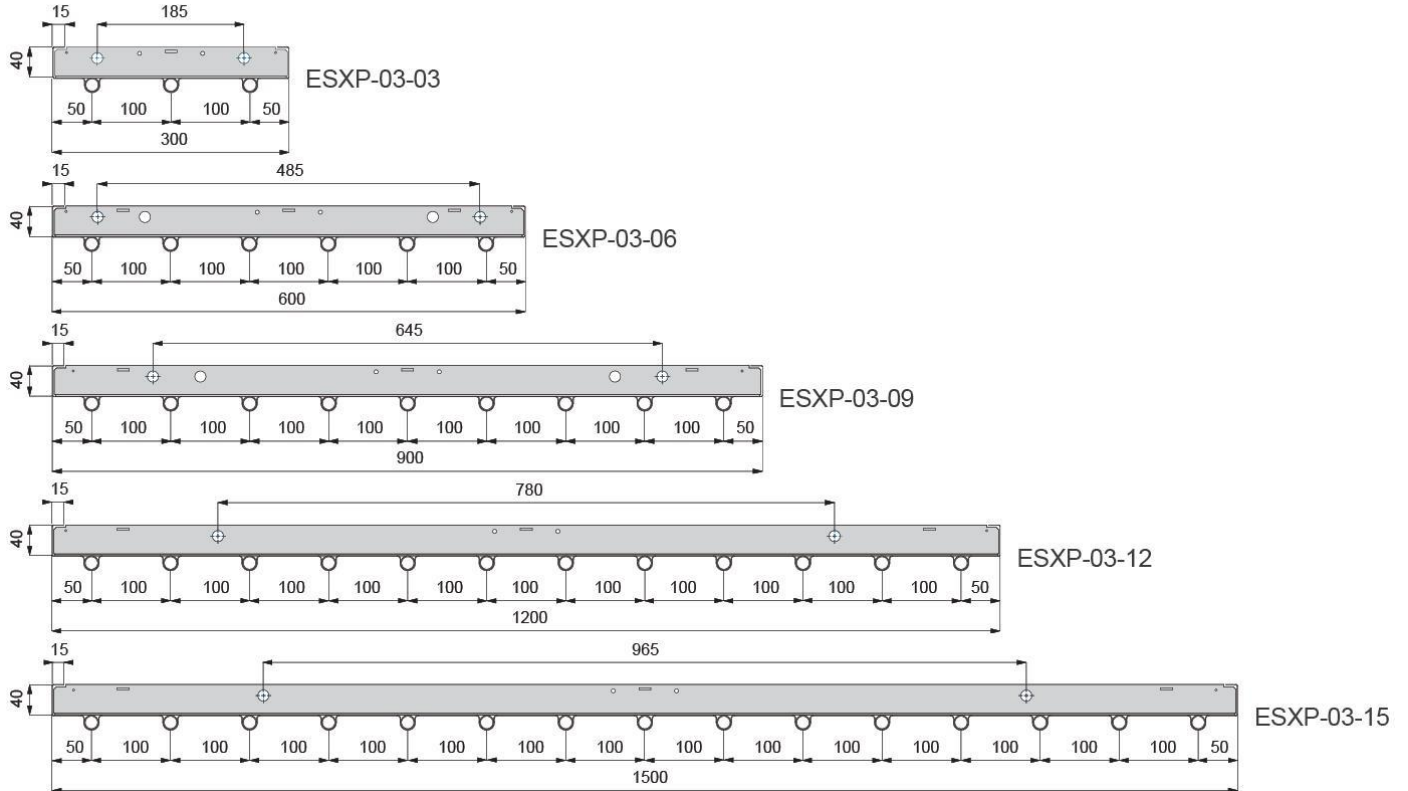

Model ESXP-04 - Ø18mm pipes spaced 75mm apart.

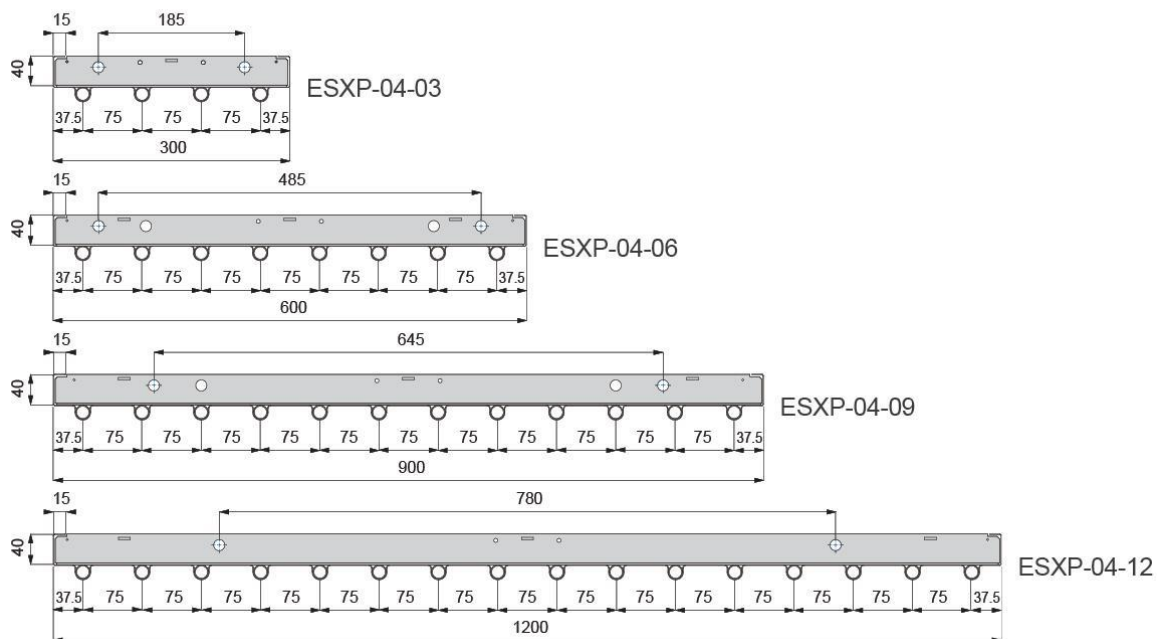

Frenger Systems Limited	11			
Riverside Road, Pride Park, Derby	Telephone	Facsimile	E-mail	Internet
DE24 8HY, United Kingdom	+44 (0) 1332 295 678	+44 (0) 1332 381 054	Technical@frenger.co.uk	www.frenger.co.uk

Panel Sections with Hanging Bracket Pitches

Start and Final Head

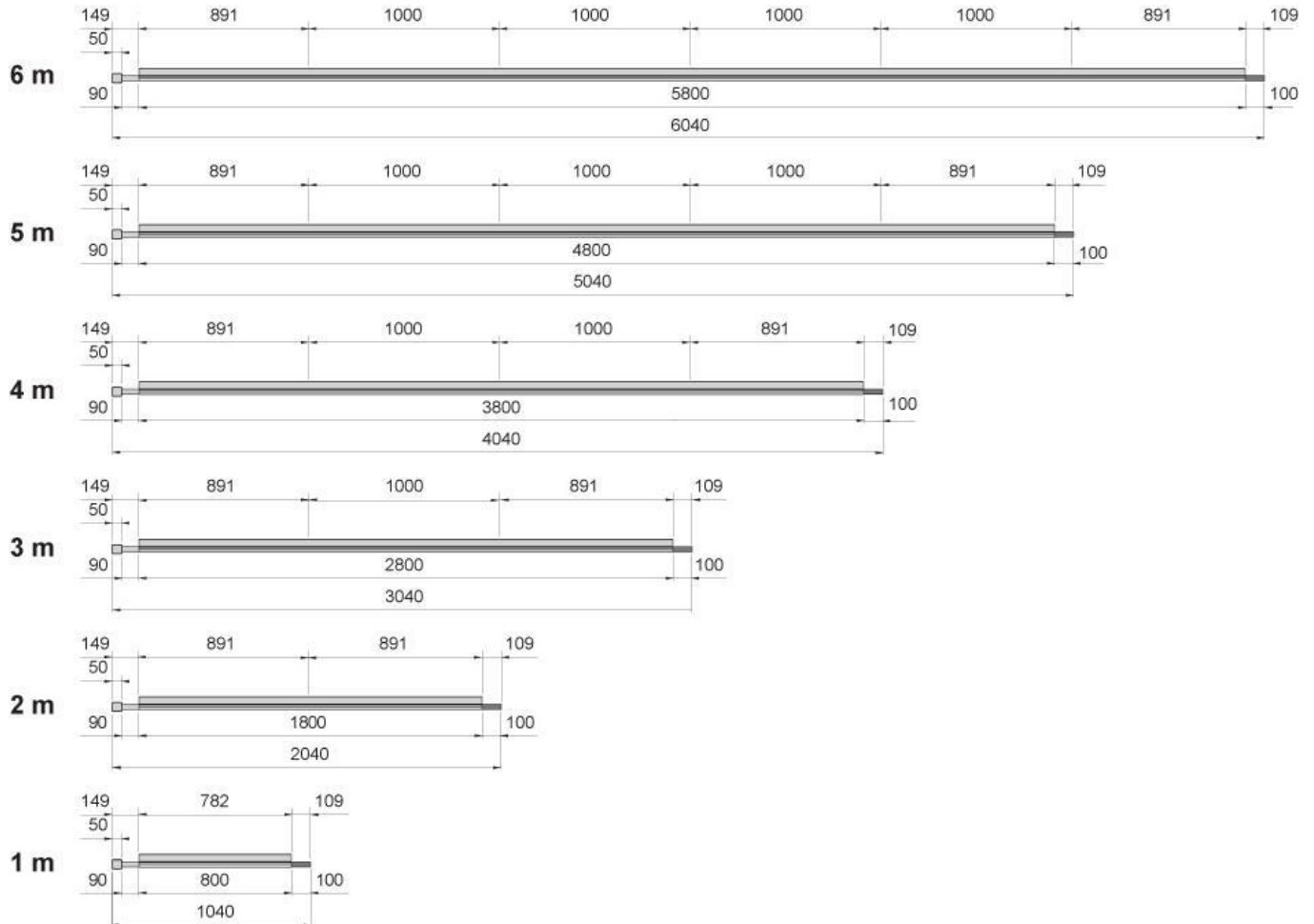

Frenger Systems Limited	12			
Riverside Road, Pride Park, Derby	Telephone	Facsimile	E-mail	Internet
DE24 8HY, United Kingdom	+44 (0) 1332 295 678	+44 (0) 1332 381 054	Technical@frenger.co.uk	www.frenger.co.uk

Intermediate

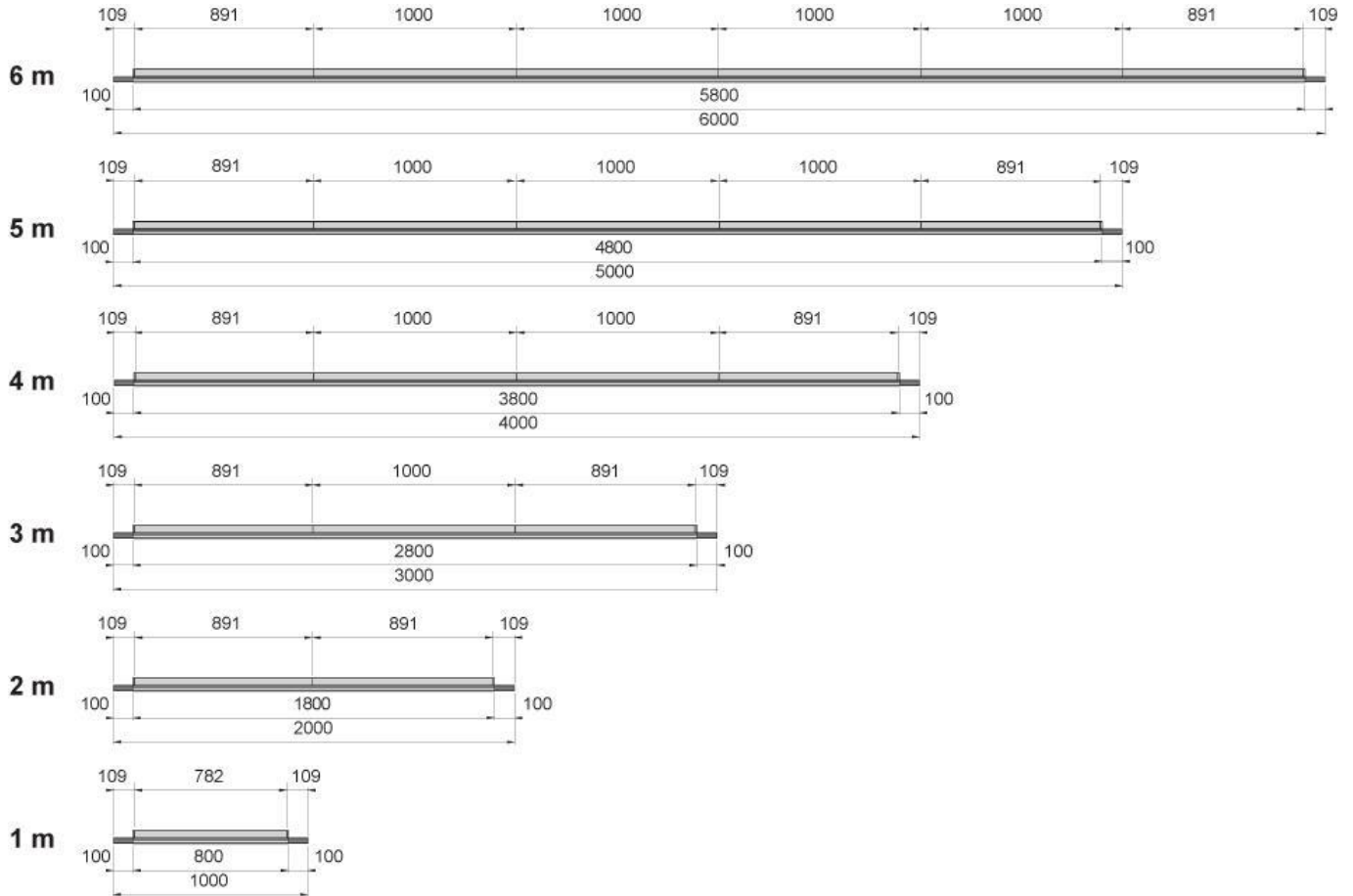

Frenger Systems Limited	13			
Riverside Road, Pride Park, Derby	Telephone	Facsimile	E-mail	Internet
DE24 8HY, United Kingdom	+44 (0) 1332 295 678	+44 (0) 1332 381 054	Technical@frenger.co.uk	www.frenger.co.uk

Double Heads

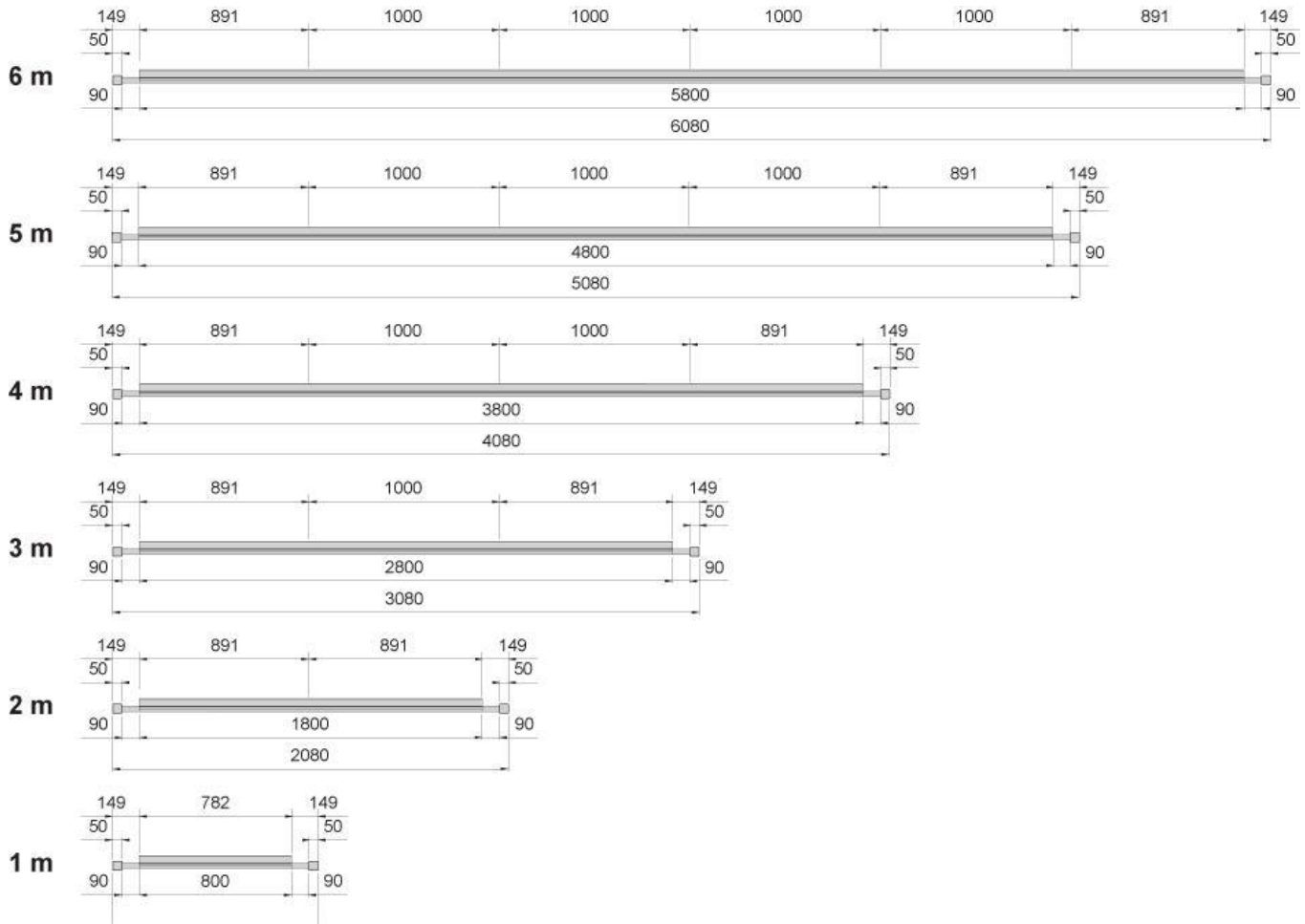

Frenger Systems Limited		14		
Riverside Road, Pride Park, Derby	Telephone	Facsimile	E-mail	Internet
DE24 8HY, United Kingdom	+44 (0) 1332 295 678	+44 (0) 1332 381 054	Technical@frenger.co.uk	www.frenger.co.uk

Header & Connections

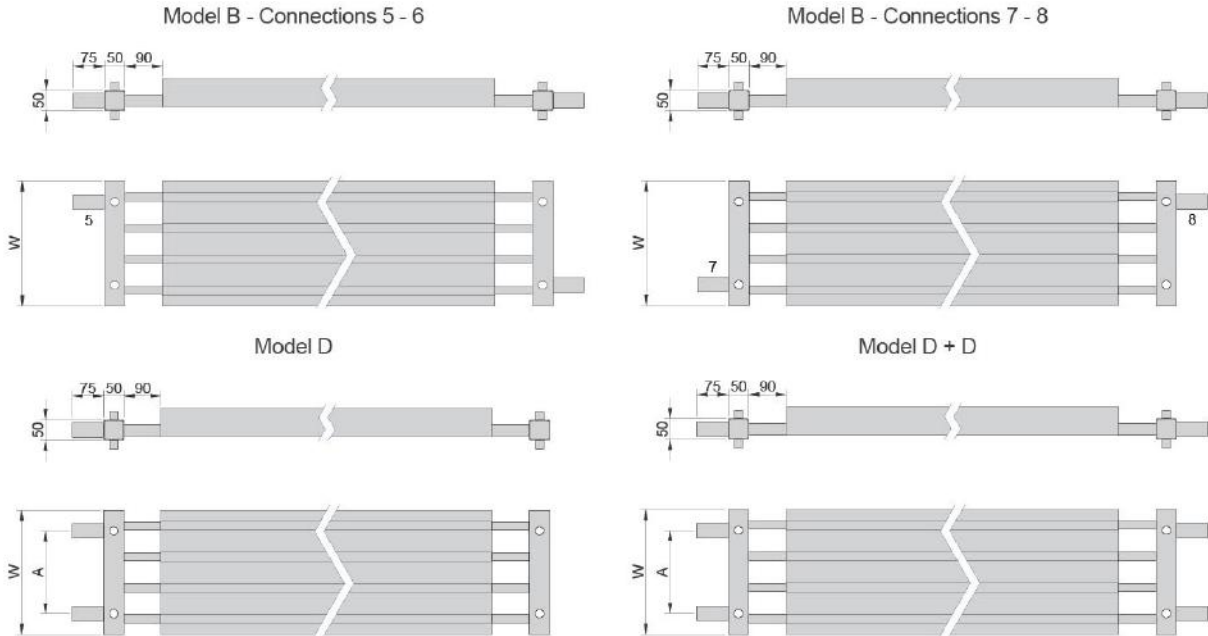

Type	W (mm)	A (mm)
ESXP-XX-03	300	200
ESXP-XX-06	600	500
ESXP-XX-09	900	800
ESXP-XX-12	1200	1100
ESXP-XX-15	1500	1400

Connection Sizes (inches)
3/4
1
1 1/4

Warning!

D and D+D headers are not suitable for high temperature hot water.

“D” header can be used with hot water up to lines with a maximum length of 50 and using slow and soft opening valves.

Weight and Water Content

Type	Radiant Panel		Header	
	Dry Weight (kg/m)	Water Content (l/m)	Dry Weight (kg/m)	Water Content (l/m)
ESXP-03-03	4.0	0.57	1.0	0.64
ESXP-03-06	8.0	1.15	2.0	1.33
ESXP-03-09	12.0	1.72	2.9	2.02
ESXP-03-12	16.0	2.29	3.8	2.71
ESXP-03-15	19.0	2.87	4.7	3.40
ESXP-04-03	5.0	0.77	1.0	0.64
ESXP-04-06	9.0	1.53	2.0	1.33
ESXP-04-09	14.0	2.29	2.9	2.02
ESXP-04-12	18.0	3.06	3.8	2.71

Frenger Systems Limited		15			
Riverside Road, Pride Park, Derby		Telephone	Facsimile	E-mail	Internet
DE24 8HY, United Kingdom		+44 (0) 1332 295 678	+44 (0) 1332 381 054	Technical@frenger.co.uk	www.frenger.co.uk

Thermal Emission

Table of thermal emission of each meter of the different models of EcoStrip XP radiant panels in accordance to European Standard EN 14037.

	ESXP-03-03	ESXP-03-06	ESXP-03-09	ESXP-03-12	ESXP-03-15	ESXP-04-03	ESXP-04-06	ESXP-04-09	ESXP-04-12
Δt_m (K)	W/m	W/m	W/m	W/m	W/m	W/m	W/m	W/m	W/m
20	61.2	106.4	152.3	188.3	235.3	67.6	109.4	159.1	198.3
25	79.5	137.1	197.1	244.8	304.9	87.6	143.0	206.8	258.9
30	98.4	168.7	243.4	303.3	376.8	108.1	177.9	256.1	321.9
35	117.9	201.0	290.8	363.7	450.6	129.2	214.0	306.9	387.0
40	137.8	233.9	339.3	425.5	526.2	150.7	251.1	359.0	454.0
45	158.2	267.4	388.8	488.8	603.3	172.7	289.2	412.2	522.7
46	162.3	274.2	398.8	501.6	618.9	177.2	296.9	423.0	536.6
47	166.4	281.0	408.8	514.4	634.6	181.6	304.7	433.8	550.6
48	170.6	287.8	418.9	527.3	650.3	186.1	312.5	444.7	564.6
49	174.8	294.6	429.0	540.3	666.1	190.6	320.3	455.6	578.7
50	178.9	301.5	439.1	553.3	681.9	195.1	328.1	466.5	592.8
51	183.1	308.3	449.3	566.3	697.7	199.6	336.0	477.5	607.0
52	187.4	315.2	459.5	579.4	713.7	204.2	343.9	488.5	621.3
53	191.6	322.1	469.7	592.5	729.6	208.7	351.9	499.5	635.6
54	195.8	329.0	479.9	605.7	745.6	213.3	359.8	510.6	649.9
55	200.1	335.9	490.2	618.9	761.7	217.8	367.8	521.8	664.4
56	204.3	342.9	500.5	632.2	777.8	222.4	375.9	532.9	678.8
57	208.6	349.9	510.9	645.5	794.0	227.0	383.9	544.1	693.3
58	212.9	356.9	521.2	658.8	810.2	231.6	392.0	555.3	707.9
59	217.2	363.9	531.6	672.2	826.4	236.3	400.1	566.6	722.5
60	221.5	370.9	542.1	685.6	842.7	240.9	408.3	577.9	737.2
61	225.9	377.9	552.5	699.1	859.0	245.5	416.4	589.2	751.9
62	230.2	385.0	563.0	712.6	875.4	250.2	424.6	600.5	766.6
63	234.5	392.0	573.5	726.1	891.8	254.9	432.9	611.9	781.4
64	238.9	399.1	584.0	739.7	908.3	259.5	441.1	623.3	796.3
65	243.3	406.2	594.6	753.3	924.8	264.2	449.4	634.8	811.2
66	247.7	413.3	605.2	767.0	941.3	268.9	457.7	646.3	826.1
67	252.1	420.4	615.8	780.6	957.9	273.7	466.0	657.8	841.1
68	256.5	427.6	626.4	794.4	974.5	278.4	474.3	669.3	856.1
69	260.9	434.7	637.1	808.1	991.2	283.1	482.7	680.9	871.2
70	265.3	441.9	647.7	821.9	1007.9	287.9	491.1	692.5	886.3
75	287.7	478.0	701.5	891.4	1092.0	311.8	533.4	750.9	962.5
80	310.2	514.3	755.8	961.7	1177.0	335.9	576.3	810.0	1039.7
85	333.1	551.0	810.6	1032.8	1262.8	360.3	619.8	869.8	1117.9
90	356.1	588.0	865.9	1104.7	1349.5	384.9	663.7	930.1	1196.9
95	379.4	625.3	921.8	1177.2	1437.0	409.8	708.1	991.1	1276.8
100	402.8	662.8	978.0	1250.4	1525.2	434.8	753.0	1052.6	1357.6

Δt_m (K) = difference between the mean water temperature and the room temperature

Frenger Systems Limited		16			
Riverside Road, Pride Park, Derby		Telephone	Facsimile	E-mail	Internet
DE24 8HY, United Kingdom		+44 (0) 1332 295 678	+44 (0) 1332 381 054	Technical@frenger.co.uk	www.frenger.co.uk

Table of thermal emission of a Couple of Headers of the different models in accordance to European Standard EN 14037.

Δt_m (K)	ESXP-03-03	ESXP-03-06	ESXP-03-09	ESXP-03-12	ESXP-03-15	ESXP-04-03	ESXP-04-06	ESXP-04-09	ESXP-04-12
	W/m	W/m	W/m	W/m	W/m	W/m	W/m	W/m	W/m
20	29.6	60.7	91.5	119.8	150.3	35.4	67.5	106.4	139.8
25	38.9	79.3	119.6	157.4	197.1	46.5	89.4	139.9	184.7
30	48.7	98.6	148.8	196.7	245.9	58.2	112.5	175.0	232.0
35	58.8	118.5	178.9	237.5	296.4	70.4	136.6	211.4	281.2
40	69.3	139.0	209.9	279.7	348.6	82.9	161.6	249.0	332.2
45	80.1	160.0	241.8	323.1	402.1	95.9	187.4	287.7	384.9
46	82.3	164.3	248.2	331.9	413.0	98.5	192.7	295.6	395.6
47	84.5	168.5	254.7	340.7	423.9	101.1	198.0	303.5	406.4
48	86.7	172.8	261.2	349.6	434.9	103.8	203.3	311.4	417.2
49	88.9	177.1	267.7	358.6	445.9	106.5	208.7	319.4	428.1
50	91.1	181.5	274.3	367.5	457.0	109.1	214.0	327.4	439.0
51	93.4	185.8	280.8	376.5	468.1	111.8	219.4	335.5	450.0
52	95.6	190.2	287.5	385.6	479.2	114.5	224.9	343.6	461.1
53	97.9	194.5	294.1	394.7	490.4	117.2	230.3	351.7	472.2
54	100.2	198.9	300.7	403.8	501.7	120.0	235.8	359.8	483.3
55	102.5	203.3	307.4	413.0	513.0	122.7	241.3	368.0	494.5
56	104.8	207.8	314.1	422.2	524.3	125.5	246.9	376.3	505.8
57	107.1	212.2	320.9	431.4	535.7	128.2	252.4	384.5	517.1
58	109.4	216.7	327.6	440.7	547.1	131.0	258.0	392.8	528.4
59	111.7	221.1	334.4	450.0	558.6	133.8	263.7	401.1	539.8
60	114.0	225.6	341.2	459.4	570.1	136.6	269.3	409.5	551.3
61	116.4	230.1	348.0	468.8	581.7	139.4	275.0	417.9	562.8
62	118.7	234.6	354.9	478.2	593.2	142.2	280.7	426.3	574.3
63	121.1	239.2	361.7	487.7	604.9	145.0	286.4	434.7	585.9
64	123.4	243.7	368.6	497.1	616.5	147.8	292.1	443.2	597.6
65	125.8	248.3	375.5	506.7	628.2	150.7	297.9	451.7	609.2
66	128.2	252.8	382.4	516.2	640.0	153.5	303.6	460.3	621.0
67	130.6	257.4	389.4	525.8	651.8	156.4	309.5	468.8	632.7
68	133.0	262.0	396.4	535.4	663.6	159.3	315.3	477.4	644.6
69	135.4	266.6	403.4	545.1	675.5	162.2	321.1	486.1	656.4
70	137.8	271.2	410.4	554.8	687.4	165.1	327.0	494.7	668.3
75	150.0	294.6	445.7	603.6	747.4	179.7	356.7	538.4	728.5
80	162.3	318.2	481.5	653.2	808.2	194.5	386.9	582.8	789.6
85	174.9	342.1	517.8	703.5	869.9	209.6	417.6	627.7	851.7
90	187.6	366.2	554.5	754.5	932.4	224.8	448.8	673.3	914.8
95	200.5	390.7	591.6	806.1	995.6	240.3	480.4	719.5	978.7
100	213.5	415.4	629.1	858.4	1059.5	255.9	512.5	766.2	1043.4

Δt_m (K) = difference between the mean water temperature and the room temperature

Frenger Systems Limited		17		
Riverside Road, Pride Park, Derby	Telephone	Facsimile	E-mail	Internet
DE24 8HY, United Kingdom	+44 (0) 1332 295 678	+44 (0) 1332 381 054	Technical@frenger.co.uk	www.frenger.co.uk

Maintenance and Cleaning

A visual inspection of all the EcoStrip XP surfaces and connections should be made on an annual basis; any surfaces that require cleaning should be wiped with a damp cloth to remove dust and debris to prevent any build-up that could impinge upon the radiant heating panels performance..

The anticipated frequency for cleaning is normally 2-3 years, albeit the required frequency will be dependant upon the environment in which the panels are suspended, and should therefore be determined by the maintenance personnel during the annual inspections.

Water Quality

The heating water system should be filled using potable water with a pH between 6 and 9; in hardwater areas the water should be softened to avoid excessive scale, but the total hardness should be kept above 60ppm of CaCO₃ to prevent corrosion caused by aggressive water.

Additive inhibitors and chemical treatments will be required to ensure that the oxygen content is maintained less than 0.5mg/l, the inhibitors should also prevent microbiological contamination and scaling. The inhibitors and chemical treatments must be appropriate to use with mild / low carbon steel and the water treatment must be maintained within the inhibitor manufacturers specified control parameters; the correct system dosing and chemicals used are the responsibility of the installer and maintenance personnel.

To ensure the correct water quality is maintained we recommend that the water quality should initially be monitored on a bi-weekly frequency during the first 2 months following installation, then monitored every 4 months thereafter.

Replacement Parts

EcoStrip XP radiant heating panels contain no serviceable or consumable parts.

All panels run have an identification label positioned on the front and end headers:

ecostrip XP		QUALITY CONTROL		CE-18		EN 14037-1	
by frenger systems		Riverside Road-Pride Park-DE24 8HY		DOP-ECOXP-FSL-011			
ESXP	3-03	3-06	3-09	3-12	3-15	4051151FR	
	<input type="checkbox"/>	<input type="checkbox"/>	<input type="checkbox"/>	<input type="checkbox"/>	<input type="checkbox"/>		
ESXP	4-03	4-06	4-09	4-12			
	<input type="checkbox"/>	<input type="checkbox"/>	<input type="checkbox"/>	<input type="checkbox"/>			

Example Panel Identification Label

Frenger Systems Limited	18			
Riverside Road, Pride Park, Derby	Telephone	Facsimile	E-mail	Internet
DE24 8HY, United Kingdom	+44 (0) 1332 295 678	+44 (0) 1332 381 054	Technical@frenger.co.uk	www.frenger.co.uk

Contact Details

In the event that further information is required please contact Frenger Systems stating the Project Name; Frenger System's contact details are as follows:

Frenger Systems Limited
Riverside Road
Pride Park
Derby
DE24 8HY

Tel: +44 (0)1332 295 678
Fax: +44 (0)1332 318 054
sales@frenger.co.uk
Web: www.frenger.co.uk

Frenger Systems Limited	19			
Riverside Road, Pride Park, Derby	Telephone	Facsimile	E-mail	Internet
DE24 8HY, United Kingdom	+44 (0) 1332 295 678	+44 (0) 1332 381 054	Technical@frenger.co.uk	www.frenger.co.uk